

# AEX

CONVENTION SERVICES

2012 EXHIBITOR KIT



ATLANTIC CITY ANTIQUE  
AND COLLECTORS SHOW  
ATLANTIC CITY CONVENTION CENTER  
MARCH 10-11, 2012

**Show Name:** ATLANTIC CITY ANTIQUE AND COLLECTORS SHOW

**Show Dates:** MARCH 10-11, 2012

**Show Location:** ATLANTIC CITY CONVENTION CENTER - HALL D

**Deadline Date To Receive Discounted Rates:** MARCH 2, 2012

**EXHIBITOR DRIVE-IN HOURS:**

<b>THURSDAY</b>	<b>MARCH 8, 2012</b>	<b>8:00 AM - 6:00 PM</b>
<b>FRIDAY</b>	<b>MARCH 9, 2012</b>	<b>8:00 AM - 6:00 PM</b>

**EARLY BUYING HOURS**

<b>SATURDAY</b>	<b>MARCH 10, 2012</b>	<b>9:00 AM - 10:00 AM</b>
-----------------	-----------------------	---------------------------

**PUBLIC SHOW HOURS**

<b>SATURDAY</b>	<b>MARCH 10, 2012</b>	<b>10:00 AM - 6:00 PM</b>
<b>SUNDAY</b>	<b>MARCH 11, 2012</b>	<b>11:00 AM - 5:00 PM</b>

**EXHIBITOR MOVE-OUT HOURS**

<b>SUNDAY</b>	<b>MARCH 11, 2012</b>	<b>5:00 PM - 11:59 PM</b>
---------------	-----------------------	---------------------------

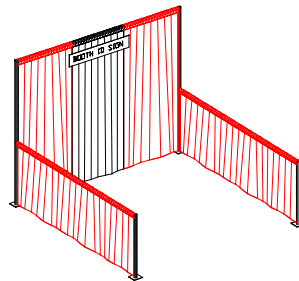

**BOOTH EQUIPMENT**

Each booth will be provided with an 8' BLACK background drape and 42" BLACK side divider drapes.

**ASSISTANCE**

If you have any questions or would like assistance, please call our office at (609) 272-1600.

**WE APPRECIATE YOUR BUSINESS**

**Show Name:** ATLANTIC CITY ANTIQUE AND COLLECTORS SHOW

**Show Dates:** MARCH 10-11, 2012

**Show Location:** ATLANTIC CITY CONVENTION CENTER - HALL D

**Deadline Date To Receive Discounted Rates:** MARCH 2, 2012

# **ATTENTION**

# **EXHIBITORS**

**Please be advised that all of AEX's inventory will be closely monitored. Items are rented and are to be left in your booth at the close of the show.**

**Thank you**

**Show Name:** ATLANTIC CITY ANTIQUE AND COLLECTORS SHOW

**Show Dates:** MARCH 10-11, 2012

**Deadline Date To Receive Discounted Rates:** MARCH 2, 2012

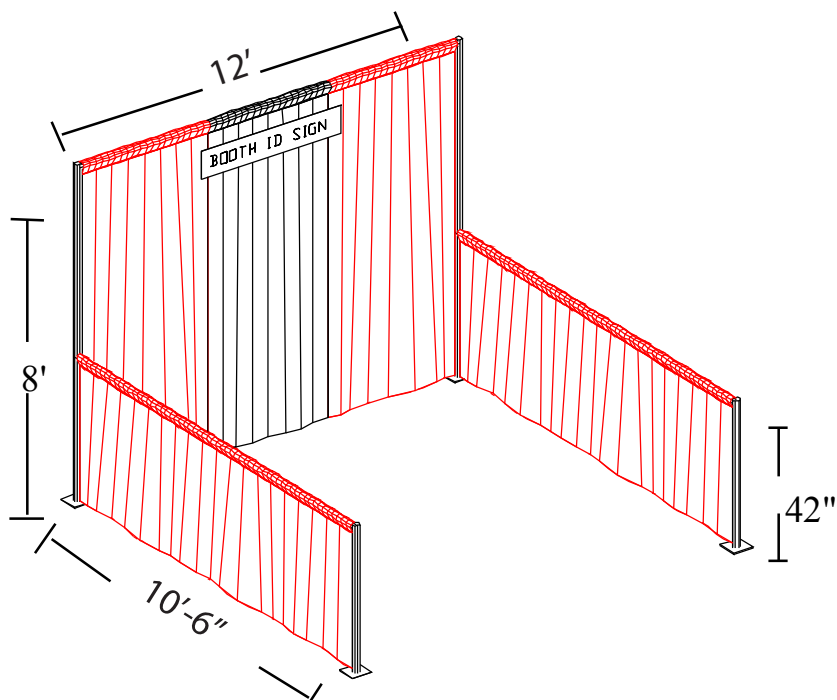

REAR BACKGROUND - 8' HIGH  
BLACK

SIDE DIVIDERS - 42" HIGH  
BLACK

SIGN  
Booth ID sign is 7" high by 44" long.

PIPE AND DRAPE  
BOOTH ID SIGN

There is no charge to the exhibitor for this equipment.

AEX Convention Services is pleased to offer services and rentals including; rental furniture; modular exhibits; specialty furniture; grid wall; carpet; perfboards; tack boards; showcases; banners & artwork; floral; photography; labor; forklift and rigging; and, cleaning service etc. If you are interested in service or rentals not in this Exhibitor Kit, please contact our office at (609) 272-1600.



**LIMITS & LIABILITIES AND TERMS AND CONDITIONS  
BY USING OUR SERVICES OR SIGNING THE AGREEMENT TO TERMS AND CONDITIONS, YOU AND YOUR  
COMPANY AGREE TO THE FOLLOWING**

**DRAYAGE/FREIGHT RATES APPLY** to each pound with a minimum (see Material Handling Order Form for actual minimum) and are based on the actual or estimated **INBOUND** weight. No allowance will be made for weight reductions during the event. Each shipment is considered separately. **NO** cumulative weights will be allowed on minimums, split shipments, etc.

**SHIPMENTS OF EQUIPMENT REQUIRING SPECIAL HANDLING** at the facilities will be subject to a surcharge as indicated on the freight rate schedule. This classification shall be applied to, but not limited to, van line shipments or shipments which are packed in such a manner as to require unloading by hand (e.g., loose display parts, uncrated equipment, etc.) Material will be unloaded from vans, exhibitor's truck, or trucks of others at the facility, delivered to the Exhibitor's booth, picked up at the close of the show, moved to the loading area and reloaded. The Exhibitor must provide written and accurate weight information on each shipment. Shipments received without Certified Weight Tickets or Bills of Lading, such as UPS, Fed. Ex. or U.S. Mail, will be delivered to the booth without guarantee of piece count or condition. AEX Convention Services assumes no liability for such shipments.

**SPECIAL SERVICES AND RATES** - Steel banding for the packing of displays and equipment is available at the AEX Convention Services service desk for \$2.00 per linear ft. plus labor at prevailing rates. Forklifts and drivers are available for spotting equipment in the booth at prevailing rates for equipment and labor. Shrink-Wrap is available at a flat rate of \$55.00 per 4'x4'x4' pallet, thereafter pro-rata.

**EMPTY CONTAINER STORAGE** - Properly labeled empty containers of freight handled by AEX Convention Services will be removed and returned to the booth; "empty" labels will be available at the service desk. Affixing labels is the sole responsibility of the Exhibitor or representative who must remove or obliterate all old labels. AEX Convention Services assumes no responsibility for containers with old empty storage labels or without AEX Convention Services labels, improper information on empty labels or valuables stored in such containers. Handling of empty containers of freight not brought in by AEX Convention Services will be charged \$25.00 per box or crate each way.

**OUTBOUND SHIPPING INSTRUCTIONS** should be given to AEX Convention Services once shipment is packed and ready to be loaded. All bills of lading and shipping instructions covering outbound shipments will be checked at the time of actual loading and corrections made where discrepancies exist. Freight remaining on the exhibit floor without proper instructions for disposition will be removed by AEX Convention Services and shipped with the information available at the time using a carrier of AEX Convention Service's choice or at our sole discretion brought to AEX's warehouse, where storage and handling will be charged for such items. AEX Convention Services will not be liable for shipping errors. The condition, count, and contents of the materials found in the booth at the time of actual removal will be final and binding and the right is reserved to alter exhibitor's bill of lading to reflect actual condition, count, and content found.

**LIMITATIONS OF LIABILITY** - AEX Convention Services IS NOT responsible for damage to materials improperly packed, concealed damage, loss or theft of Exhibitors' material after same has been delivered to your booth, or before materials have been picked up for loading out of the booth. AEX Convention Services makes no warranties or claims except as may be set forth in these terms and conditions. No oral modifications may be made to these terms. Regardless of your claim, AEX Convention Service's liability with respect to your freight or any damage whatsoever, is limited to \$.30 per pound/per article, with a maximum of \$50.00 per item, and a maximum of \$1,000.00 per shipment, even in the event of AEX Convention Service's negligence. AEX's liability for any damages whatsoever when you hire us for supervised installation/dismantle is limited to the actual cost for supervision.

**EXHIBIT LOSS OR DISAPPEARANCE** - AEX Convention Services and its subcontractors ARE NOT responsible for loss or disappearance of Exhibitor's material after such material has been delivered to the Exhibitor's booth. Relative to inbound shipments, there may be a lapse of time between the delivery of shipment(s) to the applicable booth by AEX Convention Services or its subcontractors, and the arrival of Exhibitor's representative at the booth. During such time the shipment(s) will be left unattended in the booth. AEX Convention Services or its subcontractors shall not be responsible for any loss or damage that may occur during such a period.

Similarly, AEX Convention Services and its subcontractors ARE NOT responsible for loss or disappearances of Exhibitor's material before Exhibitor's material is picked up from the Exhibitor's booth for loading after the exhibition. All bills-of-lading covering outgoing shipment that are given to AEX Convention Services by the Exhibitor will be checked at the time of pick-up from the booth, and corrections will be made at such time if discrepancies exist. Relative to outgoing shipments, it is possible that there will be a lapse of time between the completion of the packing and the pick up material from the booths for loading. AEX Convention Services and its subcontractors are not responsible for any loss or damage that may occur during such period.

**DISPUTES** - In the event of any dispute between an Exhibitor and AEX Convention Services relative to any loss or damage to such Exhibitor's material, such Exhibitor shall not be entitled to and shall not withhold payment of any amount due to AEX Convention Services for services or rentals provided as any offset against the amount of any alleged loss or damage. Instead, such Exhibitor shall pay AEX Convention Services for any rental or services and Exhibitor may pursue any claim against AEX Convention Services independently. No claims for loss or damage will be considered until payment in full for all services performed by AEX Convention Services has been received.

**INSURANCE** - Exhibitors agree to carry all-risk floater insurance covering their material against damage, loss, theft and all hazards which covers from the time shipment is made prior to show until shipments are returned to Exhibitor after the show.

We require full payment with order for rentals, service, tax and anticipated freight. This form, with your credit card information for payment of advance and show site orders, must be completed, mailed or faxed to AEX Convention Services in order for us to provide any rentals or services. Full payment must accompany your order to qualify for the discounted rates. A \$35.00 surcharge will be added to your account if any credit charges are denied or if any checks are returned. Unpaid account will accrue a service charge of 1.5% per month. Exhibitor agrees to be responsible for all fees connected with the collection of its accounts.



# FURNITURE RENTAL ORDER FORM

Please Mail or Fax Completed Form to: AEX Convention Services  
 3089 English Creek Ave., Egg Harbor Township, NJ 08234  
 Fax: (609) 272-1680 • Phone: (609) 272-1600  
 www.aexservices.com

**Show Name:** ATLANTIC CITY ANTIQUE AND COLLECTORS SHOW

**Show Dates:** MARCH 10-11, 2012

**Deadline Date To Receive Discounted Rates:** MARCH 2, 2012

**Company Name:** \_\_\_\_\_ **Booth#:** \_\_\_\_\_

## FURNITURE

Description	Discount	Standard	Qty.	Total
Plastic Side Chair	\$21.50	\$30.00	_____	_____
Padded Arm Chair	\$37.50	\$52.50	_____	_____
Padded Counter Stool	\$41.25	\$57.75	_____	_____
Cocktail Table 42" H	\$66.75	\$93.50	_____	_____
Wastebasket	\$17.75	\$25.00	_____	_____
8' Crossbar	\$26.00	\$36.50	_____	_____
8' Upright with Base	\$26.75	\$37.50	_____	_____

## UNDRAPED WOOD TABLES 30" HIGH

Description	Discount	Standard	Qty.	Total
4'L x 24"W	\$16.00	\$22.50	_____	_____
6'L x 24"W	\$25.50	\$35.75	_____	_____
6'L x 30"W	\$26.75	\$37.50	_____	_____
8'L x 24"W	\$29.22	\$40.50	_____	_____
8'L x 30"W	\$32.25	\$45.25	_____	_____

## DRAPED DISPLAY TABLES 30" HIGH (Price includes top covered with white plastic and 3 sides draped)

Description	Discount	Standard	Qty.	Total
4'L x 24"W	\$63.00	\$88.25	_____	_____
6'L x 24"W	\$71.00	\$99.50	_____	_____
6'L x 30"W	\$72.25	\$101.25	_____	_____
8'L x 24"W	\$78.00	\$109.25	_____	_____
8'L x 30"W	\$79.50	\$111.50	_____	_____
4th Side Drape 30"	\$15.75	\$26.25	_____	_____

- Please select color:**
- Burgundy
  - Blue
  - Teal
  - Black
  - Purple
  - Gray
  - Gold
  - Green
  - White
  - Red

## DRAPES (Drape rates are per linear foot)

Description	Discount	Standard	Qty.	Total
8' Background Drape / lin. ft.	\$18.25	\$25.75	_____	_____
Side Rail Drape 42"h. / lin. ft.	\$15.00	\$21.00	_____	_____

- Please select color:**
- Burgundy
  - Blue
  - Teal
  - Black
  - Purple
  - Gray
  - Gold
  - Green
  - White
  - Red

FURNITURE ORDER TOTAL: \$ \_\_\_\_\_

YES, I have completed and enclosed the Authorization and Agreement to Terms and Conditions Form and I understand that all orders are subject to New Jersey State Sales tax 7%.





# CARPET RENTAL ORDER FORM

Please Mail or Fax Completed Form to: AEX Convention Services  
 3089 English Creek Ave., Egg Harbor Township, NJ 08234  
 Fax: (609) 272-1680 • Phone: (609) 272-1600  
 www.aexservices.com

**Show Name:** ATLANTIC CITY ANTIQUE AND COLLECTORS SHOW

**Show Dates:** MARCH 10-11, 2012

**Deadline Date To Receive Discounted Rates:** MARCH 2, 2012

**Company Name:** \_\_\_\_\_ **Booth#:** \_\_\_\_\_

## STANDARD BOOTH CARPET

Description	Discount	Standard	Total
9' x 10'	\$88.75	\$124.25	\$ _____
9' x 20'	\$177.50	\$248.50	\$ _____
9' x 30'	\$266.25	\$372.75	\$ _____
9' x 40'	\$355.00	\$497.00	\$ _____

- Please select color:**
- Black
  - Green
  - Blue
  - Burgundy
  - Gray
  - Lime Green
  - Red
  - Teal

**Over 9' x 40' available pro rata.**

This carpet is not designed to cover complete booth areas since the rental cost does not include seaming and the carpets are not guaranteed to be a color match. If complete exhibit area carpet is desired, see cut & lay section below.

## PADDING - PLASTIC COVERING - TAPE

Carpet Padding

\_\_\_\_\_ ft. x \_\_\_\_\_ ft. = \_\_\_\_\_ Sq. ft. @ (Discount \$1.00/sq. ft.)(Standard \$1.25/sq. ft.) = \$ \_\_\_\_\_

Plastic Covering Area

\_\_\_\_\_ ft. x \_\_\_\_\_ ft. = \_\_\_\_\_ Sq. ft. @ (Discount \$1.35/sq. ft.)(Standard \$1.65/sq. ft.) = \$ \_\_\_\_\_

Additional Carpet Tape

\_\_\_\_\_ ft. x \_\_\_\_\_ ft. = \_\_\_\_\_ Sq. ft. @ (Discount \$1.80/sq. ft.)(Standard \$2.90/sq. ft.) = \$ \_\_\_\_\_

(All prices include installation and removal) **SUBTOTAL CARPET RENTAL ORDER:** \$ \_\_\_\_\_

**YES, I have completed and enclosed the Authorization and Agreement to Terms and Conditions Form and I understand that all orders are subject to New Jersey State Sales tax 7%.**

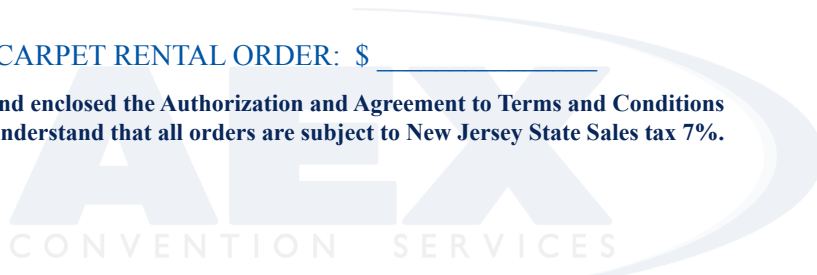

Please Mail or Fax Completed Form to: AEX Convention Services  
3089 English Creek Ave., Egg Harbor Township, NJ 08234  
Fax: (609) 272-1680 • Phone: (609) 272-1600  
www.aexservices.com

**Show Name:** ATLANTIC CITY ANTIQUE AND COLLECTORS SHOW  
**Show Dates:** MARCH 10-11, 2012  
**Deadline Date To Receive Discounted Rates:** MARCH 2, 2012

**Company Name:** \_\_\_\_\_ **Booth#:** \_\_\_\_\_

### WHITE TACKBOARD (NOT SHOWN BELOW)

Description	Discount	Standard	Qty.	Total
2' w x 8' h Wings	\$81.50	\$114.25	_____	\$ _____
4' w x 8' h Panel	\$112.25	\$157.00	_____	\$ _____

Select Style:

A       B       C

### WHITE PERFBORAD (SHOWN BELOW)

Description	Discount	Standard	Qty.	Total
2' w x 8' h Wings	\$81.50	\$114.25	_____	\$ _____
4' w x 8' h Panel	\$112.25	\$157.00	_____	\$ _____

Select Style:

A       B       C

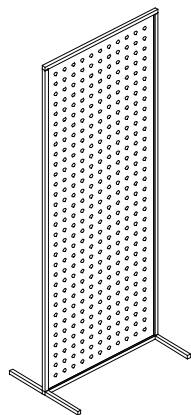

**Style "A"**  
Vertical to Floor

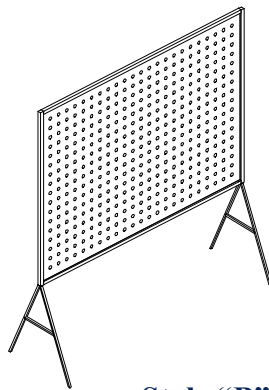

**Style "B"**  
Horizontal off Floor  
(30'' Off the Floor)

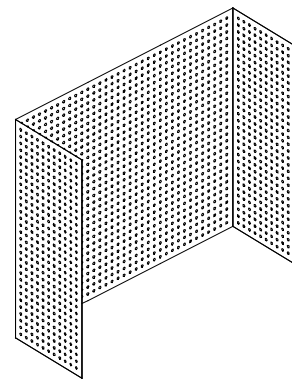

**Style "C"**  
For complete coverage of backwall

**Note:** Style "C" requires two 4' x 8' panels and three 2' x 8' panels per 10' of backwall. Depth of wings is 2'

Drawings are for illustration purpose only. Legs design may vary.  
Please order labor from the "Labor Order Form" for Style "C" or non - standard installations

SUBTOTAL GRID WALL, PERFBORAD & TACK BOARD ORDER: \$ \_\_\_\_\_

YES, I have completed and enclosed the Authorization and Agreement to Terms and Conditions Form and I understand that all orders are subject to New Jersey State Sales tax 7%.

# SHOWCASE RENTAL ORDER FORM

Please Mail or Fax Completed Form to: AEX Convention Services  
 3089 English Creek Ave., Egg Harbor Township, NJ 08234  
 Fax: (609) 272-1680 • Phone: (609) 272-1600  
 www.aexservices.com

**Show Name:** ATLANTIC CITY ANTIQUE AND COLLECTORS SHOW

**Show Dates:** MARCH 10-11, 2012

**Deadline Date To Receive Discounted Rates:** MARCH 2, 2012

**Company Name:** \_\_\_\_\_ **Booth#:** \_\_\_\_\_

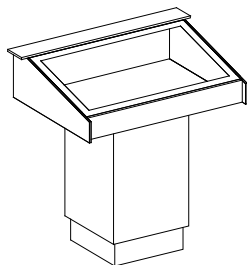

TOP VISION SHOW CASE

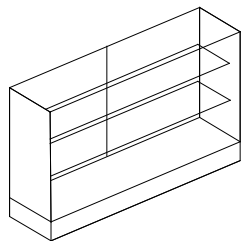

FULL VISION SHOWCASE  
(Wood Frame)

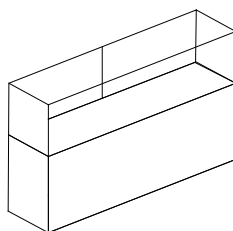

HALF VISION SHOW CASE

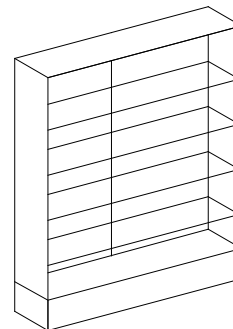

REGULAR WALL CASE

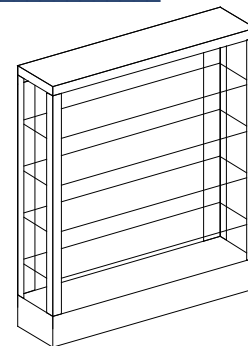

SEE-THRU WALL CASE

Glass shelves are used in these items. To prevent breakage of shelves and articles, good judgement must be used during installation and loading of glass shelves. Take care in placing heavy items or large quantities of items on these glass shelves. A sudden shock, even from small items dropped, can result in broken glass causing personal injury as well as loss of treasured valuables. AEX Convention Services does not assume responsibility for broken glass and/or personal valuables. Rental price includes delivery to and removal from your booth space.

All above are furnished with sliding glass doors and showcase light.

Electrical Orders must be placed with the **ELECTRICAL SERVICE FORM**.

**Rental price includes delivery to and removal from your booth space.**

Type	Qty.	Discount	Standard	Total
Top Vision Showcase 49" H x 39" D x 43" W	_____	\$270.50	\$378.75	_____
Full Vision Showcase 38" H x 18" D Please select 60" Wide or 72" Wide	_____	\$286.50	\$401.25	_____
Half Vision Showcase 38" H x 20" D Please select 60" Wide or 72" Wide	_____	\$286.50	\$401.25	_____
Regular Wall Case 84" H x 18" D x 70" W	_____	\$299.25	\$419.00	_____
See-Thru Wall Case 84" H x 18" D x 70" W	_____	\$305.75	\$428.00	_____
Additional Shelves	_____	\$0	\$0	_____
Locks	_____	\$27.00	\$37.75	_____

**\*\*PLEASE NOTE: THE SHOWCASE LOCATION FORM MUST BE COMPLETED ALONG WITH THIS FORM\*\***

Show Case & Wall Case Colors:

Please indicate your selection by 1st, 2nd & 3rd color choice below:

(A) Walnut/Almond (B) Black/Black (C) Black/White (D) White/White

1st Color Choice \_\_\_\_\_ 2nd Color Choice \_\_\_\_\_ 3rd Color Choice \_\_\_\_\_

**IMPORTANT:** AEX CONVENTION SERVICES will not be liable for contents, damages, or breakage after the cases have been delivered to the booths.

We will do our best to honor your selection. Priority will be given in date received/paid order. Deadline for discount/advance orders is MARCH 2, 2012 with full payment. ALL ORDERS ARE SUBJECT TO AVAILABILITY.

SUBTOTAL SHOWCASE RENTAL ORDER: \$ \_\_\_\_\_



# SHOWCASE LOCATION FORM

Please Mail or Fax Completed Form to: AEX Convention Services  
3089 English Creek Ave., Egg Harbor Township, NJ 08234  
Fax: (609) 272-1680 • Phone: (609) 272-1600  
www.aexservices.com

**Show Name:** ATLANTIC CITY ANTIQUE AND COLLECTORS SHOW

**Show Dates:** MARCH 10-11, 2012

**Company Name:** \_\_\_\_\_ **Booth#:** \_\_\_\_\_

Rental of the showcase includes a one time spotting service AT THE TIME OF DELIVERY. Please indicate on the diagram below the exact positioning of the unit. Should you request a second spotting, AEX Convention Services will charge you for that service at prevailing labor rates.



**FRONT OF BOOTH**

### CAUTION TO EXHIBITOR

Glass shelves used in this item are of Premium Quality glass. To prevent breakage of shelves and articles, good judgment must be used during installation and loading of glass shelves. Take care in placing heavy items or large quantities of items on these shelves. A sudden shock, even from a small item being dropped, can result in broken glass causing personal injury as well as loss of treasured valuables. Because the end use of the item is beyond our control AEX Convention Services cannot assume responsibility for broken glass and/or personal valuables.

**FOR OFFICE USE ONLY:**

1 OF \_\_\_\_\_

STYLE: \_\_\_\_\_

Atlantic City Antique and Collectors Show  
 March 10<sup>th</sup> & 11<sup>th</sup> 2012  
 Atlantic City, NJ

# ELECTRICAL SERVICE ORDER FORM

COPY FOR YOUR RECORDS



## ELECTRICAL

**Full payment is required to process order. Return with 100% remittance to:**

ACCC Electrical • One Convention Boulevard • Atlantic City, NJ 08401 USA • Phone (609) 449-2291 • Fax (609) 449-2464 FED ID#232511871  
**IF YOU FAX YOUR ORDER PLEASE PRINT OUT A FAX CONFIRMATION FOR YOUR RECORDS.**

COMPANY		BOOTH NUMBER	
CARDHOLDERS ADDRESS	STREET	CITY	STATE ZIP
PHONE	FAX <small>email address (invoice will be mailed at show close)</small>		
AUTHORIZED CONTACT SIGNATURE	AUTHORIZED CONTACT • PLEASE PRINT		DATE
<input type="checkbox"/> MASTERCARD <input type="checkbox"/> VISA <input type="checkbox"/> AMERICAN EXPRESS <b>EXPIRATION DATE</b>			
ACCOUNT NUMBER			
CARDHOLDER SIGNATURE	CARDHOLDER'S NAME • PLEASE PRINT		
<b>ADVANCE RATE DEADLINE DATE:          February 23<sup>rd</sup> 2012</b>			
<i>By signing and delivering this form to ACCC Electrical, customer agrees to all terms and conditions printed on this form.</i> <b>We do not accept orders without payment.</b>			

QUANTITY NON-24 HR	DESCRIPTION	ADVANCE RATE	REGULAR RATE	TOTAL
<b>120 V LIGHTING &amp; UTILITY OUTLETS</b>				
	Up to 1000 watts	\$ 120.00	\$ 180.00	
	Up to 2000 watts	\$ 150.00	\$ 225.00	

ACCCE is not responsible for voltage fluctuation or power failure due to temporary conditions. For your protection you should install a surge protector on your equipment. All electrical installations and connections to all electrical service should be made by an ACCCE electrician. ACCCE will not be responsible for any damage or loss to any equipment component, computer hardware or software and/or any damage or injury to any person caused by the installation, connection or plugging in of any electrical outlet by an ACCCE electrician.

<b>208V 1Ø MOTOR AND EQUIPMENT OUTLETS</b>				Maximum of one (1) Connection per outlet
<i>All 208V connections require labor which will be billed at show.</i>				
	20 Amp	\$ 320.00	\$ 480.00	
	30 Amp	\$ 390.00	\$ 585.00	
	60 Amp	\$ 680.00	\$ 1020.00	
	100 Amp	\$ 845.00	\$ 1270.00	
	200 Amp	\$ 1320.00	\$ 1990.00	

**IMPORTANT**

- 24-hour Power & Dedicated Circuits will be double the listed price. Please double rates. Use \* to indicate 24-HR outlet(s).
- To receive the advance rate, we must receive your order, along with payment in full or credit card authorization, on or before deadline date. All other orders will be charged at the regular rate.
- No credits will be issued on unused outlets or lights installed as ordered. Claims regarding services provided by ACCCE can not be considered unless filed by the exhibitor prior to the close of show. Cancellations must be faxed to our office three days prior to show move in. There will be a 25% surcharge on all cancellations.
- Electricity will be turned on within 30 minutes of show opening and off within 30 minutes after show closing.

**OUTLET LOCATION & DISTRIBUTION**

- All 110 volt electrical outlets will be installed on the floor at the draped backwall of inline and peninsula booths.
- All 110 volt electrical outlets for island booths will be set at one main location on the perimeter of the booth at our discretion if no floor plan provided. Labor is necessary in all Island booths.
- Any additional power locations are chargeable on a time and material basis.
- Distribution and connection of outlets are chargeable on a time and material basis. Please call regarding placement of 208 volt outlets.
- All services larger than 100 amps may be subject to an additional labor charge.

<b>208V 3Ø MOTOR AND EQUIPMENT OUTLETS</b>				Maximum of one (1) Connection per outlet
	20 Amp	\$ 395.00	\$ 590.00	
	30 Amp	\$ 465.00	\$ 690.00	
	60 Amp	\$ 745.00	\$ 1100.00	
	100 Amp	\$ 895.00	\$ 1300.00	
	200 Amp	\$ 1550.00	\$ 1950.00	

**ELECTRICAL LABOR**

- Labor rates are subject to labor contract effective at time of show.
- Labor before 8:00am and after 4:30pm and Saturdays, Sundays and holidays will be at the overtime rate.
- Electricity Labor Rates: \$113.00 per hour Regular Time, \$226.00 per hour Overtime. Labor is billed in half-hour increments with a minimum of one hour. Dismantle labor is half that of the total installation labor. Overtime labor will be charged for shows closing @ 2pm.
- Forklift Rates: prevailing labor rates (one hour minimum) plus \$275.00 forklift rental.
- Starting time can only be guaranteed when labor is requested for the start of the working day at 8:00am. The minimum charge per booth is one hour for installation and one-half (1/2) hour for dismantle. Time will commence per exhibitor's request. Failure to start labor at requested time will result in a one hour charge per electrician requested, unless 24-hour advance notice is provided in writing.

**ACCC ELECTRICAL JURISDICTION**  
 (Requires labor and/or material)

- All under-carpet distribution of electrical wiring.
- All distribution, light hanging or general labor in any space larger than 200 sq. ft.
- All facility overhead distribution of electrical wiring, including coaxial cable, fiber optics, twisted pair, etc., and the distribution of same from product to booth and from booth to booth.
- All connections requiring 208 volts and above.
- All motor and equipment hook-ups requiring hard wiring connections.
- Installation and/or repair of electrical fixtures.
- Installation of all computers.
- Installation of electrical motors and electrical apparatus to be energized.
- All electrical signs and headers.
- Labor is required to inspect equipment pre-wired to plug into our system.
- Exhibitors are not permitted to use power unless ordered. Exhibitors found using outlets without an order will be subject to the regular rate for outlets used.

<b>TRANSFORMER(S)</b>				Circle Outlets Requiring Boost
	Boosts 208V to 230V	\$ 165.00	\$ 230.00	

<b>480V 3Ø MOTOR AND EQUIPMENT OUTLETS</b>				Maximum of one (1) Connection per outlet
<i>All 480V connections require labor which will be billed at show.</i>				
	30 Amp	\$ 870.00	\$ 1300.00	
	60 Amp	\$ 1120.00	\$ 1635.00	

**FLOOD LIGHTS**

Price includes outlet and labor (for track and flood lights only.) Placement of floodlights is at the front corner(s) of your in-line booth.

**Any other location(s) or installation time will require an additional labor charge.**

	120 Watt	\$ 105.00	\$ 150.00	
	Dbl 120 Watt	\$ 135.00	\$ 205.00	
	250 Watt Krypton	\$ 140.00	\$ 210.00	
	<b>Overhead Quartz*</b>	\$ 355.00	\$ 540.00	

**TRACK LIGHTS Not available in all locations on the show floor.**

	4' Track w/3 Lights	\$ 154.00	\$ 245.00	\$
	Add'l 50 Watt Halogen	\$ 43.00	\$ 68.00	

**Rigging: Please call for quote.**

<b>*REQUIRES LABOR AND/OR LIFT AT ADDITIONAL CHARGE NOT AVAILABLE AT SOME LOCATIONS. FLOOR PLAN IS REQUIRED FOR QUARTZ LIGHTS.</b>	
1. SUB TOTAL	\$
2. SALES TAX 7%	\$
3. PAYMENT ENCLOSED	\$

**LABOR REQUEST FOR ELECTRICAL DISTRIBUTION:** ←

Date: \_\_\_\_\_ Time: \_\_\_\_\_

This Labor order will not be processed until we receive a completed electrical order, credit card authorization, and/or floor plan. Please indicate neighboring booth and aisle numbers.

DO NOT Proceed – Exhibitor Will Call For Labor

OK to Proceed Without Supervision – Per Attached Floor Plan

**METHOD OF PAYMENT**

Check Enclosed: No: \_\_\_\_\_  Credit Card Provide Information Above

Your credit card authorization is required for labor and material charges. For your convenience we will also charge the card for any additional amounts incurred as a result of showsite orders placed by you or your representative. All returned checks are subject to a \$30.00 fee.

**Important information on reverse side.**

**ALL CONNECTION AND LABOR RATES  
 SUBJECT TO CHANGE.**

## **ELECTRICAL CODE**

Electrical requirements for an exhibit at all convention facilities are for the safety of all exhibitors and are based on national electrical codes and local ordinances.

Too frequently, fires have been traceable to faulty wiring, sometimes because of carelessness and sometimes because of lack of understanding of the risks involved.

In the interest of public safety, exhibits at all convention facilities may be inspected to determine if any violations exist. If they are found, qualified electricians are available to correct the problem. This work will be performed on a time and material basis.

If the exhibitor does not wish to have the fault corrected, electrical service to the offending booth will not be connected.

If an exhibitor is not informed or does not understand basic safety standards for electrical wiring, an electrician should be consulted before shipment is made to convention facilities.

Serious risks are involved which can be eliminated by understanding basic requirements of safe wiring inside your booth.

For the safety of you and the public, remember these points:

- All wiring must have a 3-wire grounded cord with a minimum of #14 gauge.
- Spot or flood lighting is a hazard when lamps are too close to fabrics or other material which can be affected by heat.
- The use of clip-on sign sockets, latex or lamp cord wire in displays, or the use of 2-wire clamp on fixtures, is prohibited by order of fire prevention bureaus at trade shows and conventions.
- Zip cords or two-wire cords are ungrounded and could result in safety hazards. Their use is forbidden in all convention facilities. **Please leave all 2-wire cords at home!**

## **USE TIMESAVING WIRING METHODS AND DISTRIBUTION SYSTEM**

Whenever possible, in conformance with the electrical code, use multiconductor interconnecting cables with approved quick-connect plugs or fittings. Here is a list of the plugs that match our equipment receptacles:

- **15 amp 120 volt: Standard U-ground cord cap**
- **20 amp 208 volt 1Ø or 3 Ø: Leviton 3521-C non nema**
- **30 amp 208 volt 1Ø or 3 Ø: Leviton 3521-C non nema**
- **60 amp 208 volt 1Ø or 3Ø: Daniel Woodhead Trade Show Plug Y560P**
- **100 amp 208 Volt 1Ø or 3Ø: Litton Veam Trade Show Plug CIRO1GRH**

Exhibitors who require many standard outlets may wish to incorporate a power distribution system into their booth. Please contact our staff if you need more information. Initial hook up to distribution system and all distribution from system both 208 and 110 volt to be done by our staff.

### **COMMONLY ASKED QUESTIONS**

*Where will my outlet be located?*

There are four different types of trade show booths: Line booths, Peninsula Booths, Back-to-Back Peninsula Booths, and island booths. Each type of booth has its own standard methods of installation. In the following diagrams, the symbol ☒ represents the approximate location of power outlets.

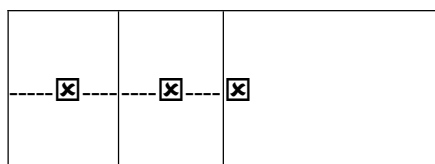

Line Booths

Peninsula Booths

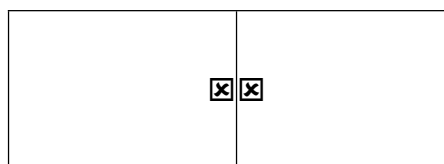

Back-to-Back Peninsula Booths



Island Booths

**Line Booths, Peninsula Booths, or Back-to-Back Peninsula Booths :** Your pre-ordered electrical outlet will be installed at the rear of your booth, at the drape line.

**Island Booths :** Your electrical outlet will be placed on the perimeter at one location at our discretion if no floorplan is submitted. Multiple outlet locations will be charged on a labor and material basis. All other distribution will be done on a time and material basis. ALL POWER IN THIS FACILITY ORIGINATES IN THE FLOOR. IF AN OVERHEAD DROP IS SPECIFICALLY REQUESTED, THERE WILL BE ADDITIONAL CHARGES FOR THE LABOR, LIFT, AND CABLE REQUIRED TO RUN THE OVERHEAD CONNECTION.

*How much power will I need?*

Calculate your lighting needs by adding wattage in each location. For other equipment, read the ratings from the metal plates attached to each unit.



120 Volt Single Phase  
50 Cycle  
1000 Watts

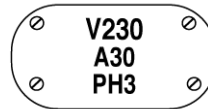

230 Volts  
30 Amps  
3 Phase

Atlantic City Antique and Collectors Show  
 March 10<sup>th</sup> & 11<sup>th</sup> 2012  
 Atlantic City, NJ

**TELECOM & INTERNET  
 SERVICE ORDER FORM**  
 COPY FOR YOUR RECORDS



**Full payment is required to process order. Return with 100% remittance to:**  
 ACCC Utilities • One Convention Boulevard • Atlantic City, NJ 08401 USA • Phone (609) 449-2291 • Fax (609) 449-2464 FED ID#232511871  
**IF YOU FAX YOUR ORDER PLEASE PRINT OUT A FAX CONFIRMATION FOR YOUR RECORDS.**

COMPANY		BOOTH NUMBER			
CARDHOLDERS ADDRESS	STREET	CITY	STATE	ZIP	COUNTRY
PHONE	FAX		email address (invoice will be mailed at show close)		
AUTHORIZED CONTACT SIGNATURE		AUTHORIZED CONTACT • PLEASE PRINT		DATE	
<input type="checkbox"/> MASTERCARD <input type="checkbox"/> VISA <input type="checkbox"/> AMERICAN EXPRESS				<b>EXPIRATION DATE</b>	
ACCOUNT NUMBER					
CARDHOLDER SIGNATURE		CARDHOLDER'S NAME • PLEASE PRINT			
QUANTITY	DESCRIPTION	ADVANCE RATE	REGULAR RATE	TOTAL	
<b>BASIC PHONE LINE</b> (includes dial 9, for voice/fax/modem, unrestricted Phone line & instrument)					
	Basic phone line	\$245.00	\$290.00		
	Hunt/Rollover & Toll restriction (price per service)	\$11.00	\$11.00		
<b>Dates of Service</b> _____					

**ADVANCE RATE  
 DEADLINE DATE:  
 February 23<sup>rd</sup> 2012**

*By signing and delivering this form to ACCC Utilities, customer agrees to all terms and conditions printed on this form.  
**Orders submitted without payment will not be processed.***

**ISDN DATA LINES** – (ISDN modem/equipment required) - **not recommended for Internet access**

	BRI-ISDN (1-B channel – 64K)	\$310.00	\$465.00	
	BRI-ISDN (2-B channel – 128K)	\$420.00	\$630.00	

**INTERNET CONNECTION** – utilizing 10MB Ethernet connection to fiber optic backbone with RJ45 twisted pair connection to the booth (Network Interface Card (NIC) required) **PLEASE RUN UPDATED ANTI VIRUS SOFTWARE ON YOUR COMPUTER BEFORE YOUR ARRIVAL AT THE FACILITY.\*\*\***

	One IP Address	\$520.00	\$780.00	
	Add'l IP Address @ same location (within same booth or mtg. Room)	\$184.00	\$276.00	

**LAN CONNECTIONS** (within booth, booth to booth, booth to mtg. Room) (does not include internet connectivity)

	LAN-10MB Ethernet	\$363.00	\$544.00	
	Add'l LAN 10MB at same location	\$79.00	\$119.00	
	LAN-100MB Ethernet	\$394.00	\$591.00	
	Add'l LAN 100MB at same location	\$84.00	\$126.00	

**IMPORTANT**

- Outgoing phone calls will be billed at the following rates: Local: \$.07/min., long distance \$.46/min., Toll free \$.50 per call.
- To receive the advance rate, we must receive your order, along with payment in full or credit card authorization, on or before deadline date. All other orders will be charged at the regular rate.
- In order to process orders in advance, locations of connections must be indicated (see diagram below). For meeting room connections, a detailed floor plan must be included. Failure to indicate location will result in your line being placed in rear of booth and/or may result in delay of service or add'l charges.
- No credits will be issued on unused phone lines installed as ordered.

Only written cancellations will be accepted and must be received seven days before show move in.

**TERMS & CONDITIONS**

- The ACCC is the exclusive provider of telecommunications for the Atlantic City Conv. Center.
- Exhibitors should pick up phone instruments at the Telecomm. Service desk.
- Exhibitors will be responsible for the protection and return of any equipment rented from ACCC. Equipment should be returned to the Service Desk at the close of the event.
- A \$100 per single line set charge and a \$300 multi-line set charge will be billed to your credit card if sets are damaged or not returned.

- A detailed statement of calls will be invoiced at the conclusion of the show and charged to the credit card provided. Credit card receipts and detail of calls will be mailed to the exhibitor.
- Telecommunications panels, floor boxes and equipment must be accessible at all times. Panels, floor boxes and equipment shall not be rendered inaccessible to ACCC Telecom personnel.
- Unless otherwise directed, ACCC techs are authorized to cut floor coverings. Telephone service is provided from floor boxes on 30-ft. centers.
- ACCC is responsible for Internet and other ACCC installed cable connections from point of demarcation to exhibitor booth. Services are limited to cable installation and IP address assignment. It is the responsibility of the exhibitor to supply connectors, connect cable to exhibitor equipment, configure exhibitor equipment and properly operate equipment. ACCC will troubleshoot ACCC installed components only.
- ACCC is not responsible for lost connections or traffic interruptions. We will work with third parties to resolve circuit issues on a best effort basis. No refunds or discounts will be given for service interruptions or other network service related downtime.
- \*\*\* THE ACCC IS NOT RESPONSIBLE FOR SERVICE INTERRUPTION DUE TO VIRUS INFECTION.**
- The exhibitor must file disputes concerning service with the Service desk prior to the close of the event.
- A minimum of \$50 will be charged to move an installed line.
- Prices subject to change without notice.
- ACCC does not allow the construction of wireless networks in the Facility.

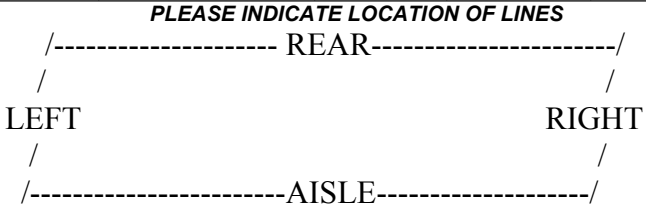

1. SUB TOTAL	\$
2. SALES TAX 7%	\$
3. PAYMENT ENCLOSED	\$

**FOR OFFICE USE ONLY:**

Exh. No. \_\_\_\_\_ Phone Ext. #: \_\_\_\_\_

Payment: \_\_\_\_\_ Date Rec'd: \_\_\_\_\_

# THE SAFE MAN, LLC

## Safe Sales & Rental

801 West Vulcanite Ave  
Alpha, NJ 08865

800-320-2589 / 908-213-3222

908-213-3022 Fax

TheSafemanllc@aol.com

24 Hr. Help 908-963-1572 Addie's cell

\*\*\*\*\*There is a limited amount of safes per model\*\*\*\*\*

Model	Description	Cubic Ft.	Inside Dimensions "H x "W x "D	Outside Dimensions "H x "W x "D	Approx. Weight Lbs.	Weekend Rental ***
2115-2	2hr. fire 2 shelves	3.2	20 x 18.5 x 15	31.5 x 25.5 x 21	420	\$280
3115-2	2hr. fire 2 shelves	4.9	30.5 x 18.5 x 15	41 x 25.5 x 21	525	\$300
3921-2	2hr. fire 2 shelves	8.9	39.5 x 18.5 x 21	50 x 25.5 x 27	760	\$320
5021-2	2hr. fire 3 shelves	11.2	50 x 18.5 x 21	60.5 x 25.5 x 27	875	\$350
6030	Burglary & fire 4 shelves	14.6	55 x 25.5 x 18	60 x 30 x 26	885	\$400
3524	TL 30 / 2 hr. fire 2 shelves	9.7	35 x 24 x 20	42 x 31 x 30	1,765	\$450
5524	TL30 / 2 hr. fire 3 shelves	15.3	55 x 24 x 20	62 x 31 x 29.5	2,475	\$550
6528	TL 30 / 2 hr. fire 4 shelves	21.1	65 x 28 x 20	72 x 35 x 29.5	3,200	\$750
6835	TL 30 / 2 hr. fire 5 shelves	32.9	68 x 35 x 25	72 x 42 x 36	4,500	\$1000
<b>COVER RENTAL</b>			<b>BLACK</b>	<b>CLOTH</b>	<b>COVER</b>	<b>\$25</b>

\*\*\*Some shows may apply a Teamster Charge (not included).



# THE SAFE MAN, LLC

801 West Vulcanite Ave

Alpha, NJ 08865

THESAFEMANLLC@AOL.COM

Phone (800) 320-2589 / 908-213-3222

Fax (908) 213-3022

PLEASE, DRAW THE SAFE INSIDE THE BOOTH, WITH THE TRIANGLE BEING THE DOOR

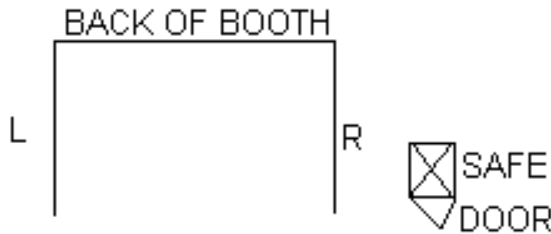

<i>Company:</i>		<i>Booth #</i>	
<i>Contact:</i>		<i>Phone:</i>	
<i>Address:</i>		<i>Fax:</i>	
<i>City:</i>		<i>State:</i>	<i>Zip:</i>
<i>Email:</i>			
Qty.	Description		Price Total
1	WEEK/END SAFE RENTAL		
****	<b>SAFE MODEL</b>		
****	<b>A CONFIRMATION OF THE ORDER WILL BE FAXED OR EMAILED. OPTIONS WILL BE GIVEN IF REQUEST IS NOT AVAILABLE.</b>		
	CREDIT CARD#:		
	EXPIRATION		
	SECURITY CODE:		
<b>TOTAL</b>			
<b>SHOW:</b>			
<b>DELIVER ON</b>		<b>PICK UP ON</b>	
<b>SAFE LOCATION IN BOOTH:(DRAW UP TOP OR DESCRIBE BELOW)</b>			

**Signature** \_\_\_\_\_

A \$25.00 fee will be charged for missing keys at the end of the show. Make sure you leave your key in or on the safe. If a cover is rented, please leave inside locked safe as well (\$150.00) Thank you!